

2-WIRE TRANSMITTER RESISTANCE – CURRENT

STI – RI



USER'S MANUAL

www.stinnovators.com

CONTENTS

1. INTRODUCTION.....	3
2. CONNECTION DIAGRAM.....	3
3. TECHNICAL DATA.....	4

1. INTRODUCTION

The 2-wire transmitter resistance-current STI - RI is designed to convert 3-wire adjustable resistance (potentiometer) into an analog current signal $4 \div 20$ mA.

STI - RI consist of the following main functional blocks and components:

- XTR106P – $4 \div 20$ mA output current source;
- 2-wire pluggable screw connection terminals for transmitter connection to the secondary device ($4 \div 20$ mA);
- 3-wire pluggable screw connection terminals for input resistance connection (potentiometer);
- LED (green), indicating the presence of output current.

2. CONNECTION DIAGRAM

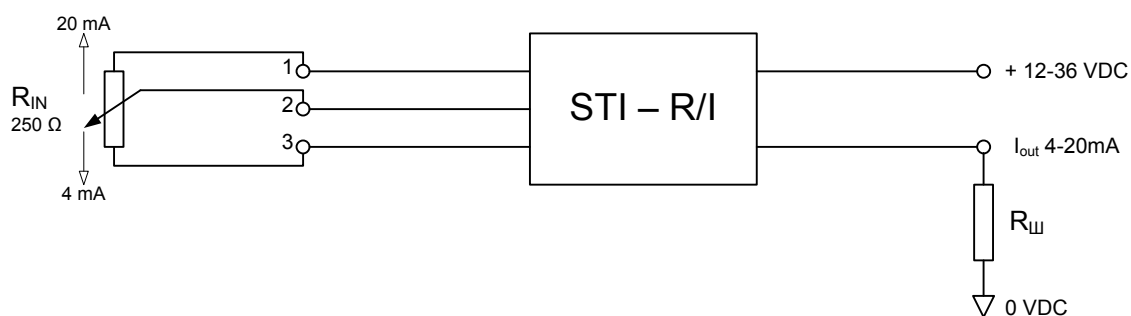

3. TECHNICAL DATA

3.1. Number of channels:	1 (one input, one output)
3.2. Input resistance:	0 ÷ 250 Ohm (or customer specified);
3.3. Output current:	4 ÷ 20 mA
3.4. Maximum relative error:	0.1% ± 1LSB
3.5. Work temperature range:	5 ÷ 45 °C
3.6. Line resistance:	700Ω at 24 VDC
3.7. Power supply:	12 ÷ 36 VDC; 100 mA
3.8. Dimensions: (W x H x D):	22,5 x 75 x 105 mm
3.9. Mounting:	35 x 7,5 mm DIN-rail

Contacts:

BULGARIA
1505, Sofia,
1, Tzarichina str.
Phone: +359 2 870 21 56, +359 888 45 99 53
Fax: +359 2 973 37 27
e-mail: office@stinnovators.com
www.stinnovators.com

